



NITROX CONTROLLER

Nitrox Controller Installation Instructions (Quick Version)

Congratulations on the purchase of your new Nitrox Controller. If you have any problems during this installation, please review the comprehensive version of the installation instructions.

Hooking it up.

1. Mount the controller to the wall using the mounting holes on the attached brackets with the provided screws/wallboard anchors.

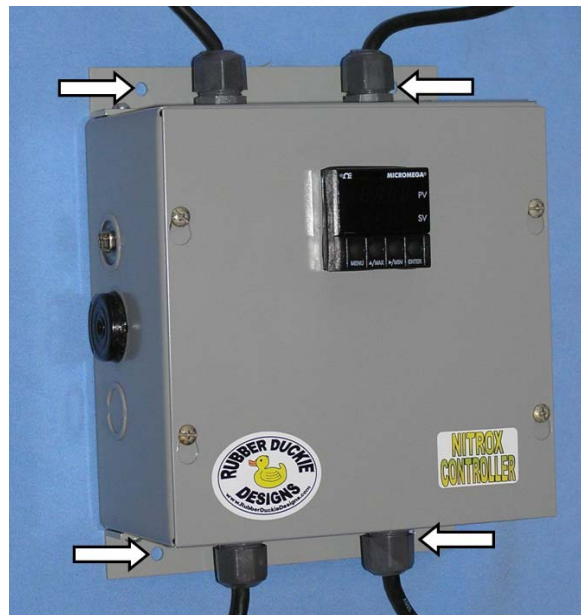

2. Install the 1-1/2 inch PVC "T" into your air system downstream of the Nitrox Mixing Stick. Thread the oxygen sensor into the flow diverter and insert the oxygen sensor and diverter into the "T". Run the appropriate wire (two wire Molex-type connector) from the Nitrox Controller to the sensor and plug it into the sensor.

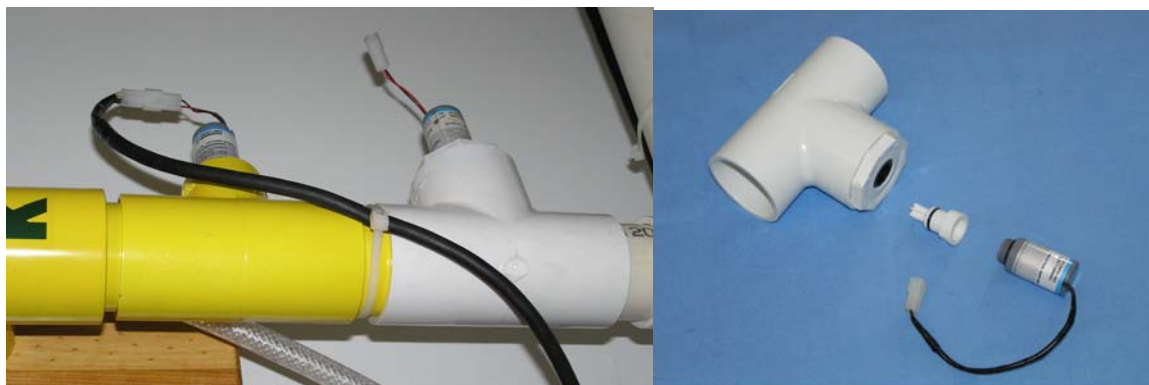

3. Install the oxygen control valve downstream of oxygen pressure regulator and metering valve. The “P” on the valve indicates the inlet. The “A” on the valve indicates the outlet. Both the inlet and outlet ports on the valve have 1/8” pipe thread. Use Teflon sealing tape. Initially shut the metering valve (you will set it in step 7 to establish the maximum flow of oxygen). Run the appropriate wire (three wire Molex-type connector) from the Nitrox Controller to the control valve and plug it into the control valve.



4. Open the electrical supply breaker to your compressor. Remove the access cover from your compressor’s electrical panel. If a small knockout is available remove it. If no knockout is available, drill a hole through the wall of the electrical panel with a 7/8” hole saw. Install the provided electrical box connector in the hole and run the shutdown wire into the electrical panel.



5. Connect the auto shutdown white wire to the compressor's 110 Volt AC negative buss. Connect the black wire to a 110 Volt AC positive terminal that is energized **only** when the compressor is running.

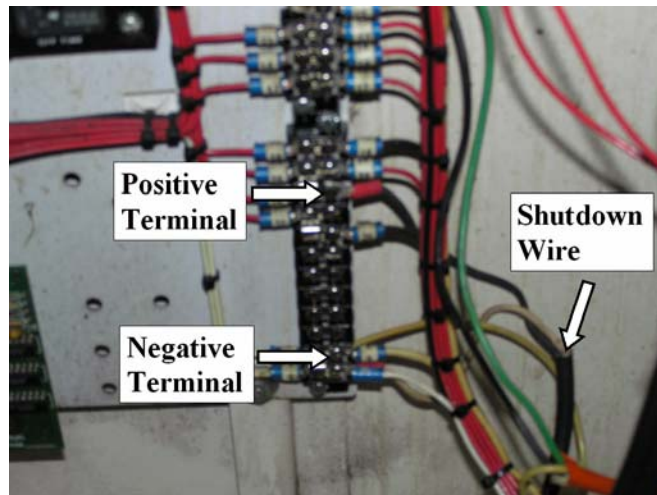

6. Plug the Nitrox Controller into a 110 Volt AC outlet. The front panel of the controller should light up and indicate the Present Value (PV) oxygen concentration (upper row, displayed in red) and Setpoint Value (SV, lower row displayed in green). The Nitrox Controller has no on/off switch, instead it has two operating modes: **Run** and **Standby** (Stby).



When the Nitrox Controller is in the **Standby** mode, to place it into the **Run** mode, press the **Enter** button once.

When the Nitrox Controller is in the **Run** mode, to place it into the **Standby** mode, press the **Enter** button twice. "Stby" will show in the lower display in green.

7. Setting the Micro Metering Valve and Oxygen Pressure Regulator.

By correctly setting the metering valve and pressure regulator, you ensure that in the event of a controller overshoot or system malfunction; you do not admit a dangerous quantity of oxygen to your air compressor.

Start with the micro-metering valve completely closed. Change the Nitrox Controller Setpoint 1 to 90% (this value is sufficiently above 40% such that the oxygen control valve will be fully open as you adjust the metering valve). Fully open the Oxygen supply valve and oxygen regulator (maximum supply pressure).

Start your air compressor and place the Nitrox Controller into **Run** by pressing the **Enter** button. The Nitrox Controller will fully open the oxygen control valve and attempt to achieve the Setpoint of 90% (which it will never reach).

Slowly open the metering valve and allow the Present Value (PV) display to stabilize. Continue to **slowly and incrementally open the metering valve** until the Present Value display just reaches 40%. This is the highest oxygen concentration at which your system can safely operate. Place the controller into **Standby**. Remove the metering valve green knob and install the valve cover. Change the Nitrox Controller Setpoint 1 to your desired setting (e.g. 32%).

You can reduce the oxygen supply to a lower pressure, but need to provide sufficient pressure for the Nitrox Controller to achieve and maintain the desired oxygen blend.

You are ready to blend Nitrox. Wasn't that easy...